

# Chaos-based communications at high bit rates using commercial fibre-optic links

Apostolos Argyris<sup>1</sup>, Dimitris Syvridis<sup>1</sup>, Laurent Larger<sup>2</sup>, Valerio Annovazzi-Lodi<sup>3</sup>, Pere Colet<sup>4</sup>, Ingo Fischer<sup>5</sup>†, Jordi García-Ojalvo<sup>6</sup>, Claudio R. Mirasso<sup>7</sup>, Luis Pesquera<sup>8</sup> & K. Alan Shore<sup>9</sup>

Chaotic signals have been proposed as broadband information carriers with the potential of providing a high level of robustness and privacy in data transmission<sup>1,2</sup>. Laboratory demonstrations of chaos-based optical communications have already shown the potential of this technology<sup>3–5</sup>, but a field experiment using commercial optical networks has not been undertaken so far. Here we demonstrate high-speed long-distance communication based on chaos synchronization over a commercial fibre-optic channel. An optical carrier wave generated by a chaotic laser is used to encode a message for transmission over 120 km of optical fibre in the metropolitan area network of Athens, Greece. The message is decoded using an appropriate second laser which, by synchronizing with the chaotic carrier, allows for the separation of the carrier and the message. Transmission rates in the gigabit per second range are achieved, with corresponding bit-error rates below  $10^{-7}$ . The system uses matched pairs of semiconductor lasers as chaotic emitters and receivers, and off-the-shelf fibre-optic telecommunication components. Our results show that information can be transmitted at high bit rates using deterministic chaos in a manner that is robust to perturbations and channel disturbances unavoidable under real-world conditions.

Broadband information carriers enhance the robustness of communication channels to interferences with narrow-band disturbances. This is the basis of spread-spectrum communication techniques, such as the code division multiple access (CDMA) protocol used in the Global Positioning System (GPS) and in the third generation of mobile telephones. In chaos-based communications the broadband coding signal is generated at the physical layer instead of algorithmically. Additionally, chaotic carriers offer a certain degree of intrinsic privacy in the data transmission, which could complement (via robust hardware encryption) both classical (software-based)<sup>6</sup> and quantum<sup>7</sup> cryptography systems. From a fundamental viewpoint, using waveforms generated by deterministic chaotic systems to carry information in a robust manner that also allows high bit rates is a generalization of standard communication systems. It might also provide a deeper insight into the mechanism of transmission of information in natural systems with complex dynamics, such as biological systems.

Chaotic communication systems based on chaos synchronization<sup>8</sup> were proposed in the early 1990s (refs 1, 2). In this type of communication protocol, messages are embedded within a chaotic carrier in the emitter, and recovered after transmission by a receiver upon synchronization with the emitter. The receiver architecture can be viewed as performing a nonlinear filtering process, intended to

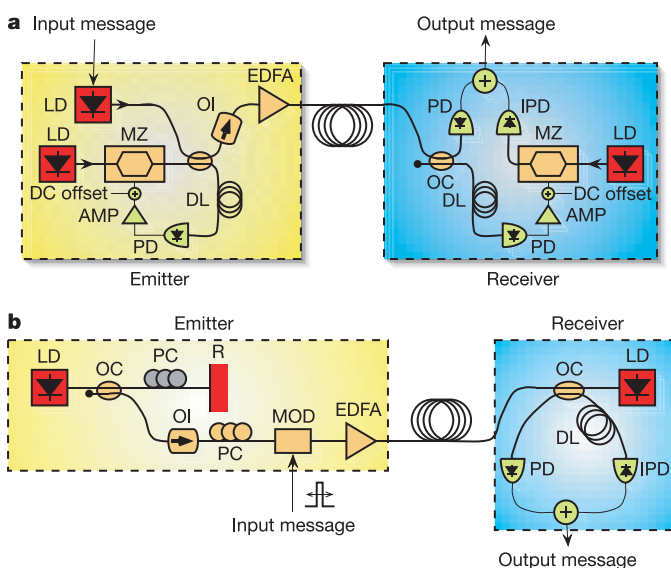

**Figure 1** | Two schematic set-ups for optical chaos communication. In the optoelectronic scheme (a), the emitter is a laser diode (LD) whose output is modulated in a strongly nonlinear way by an electro-optic feedback loop through an integrated electro-optic Mach-Zehnder interferometer (MZ). The message is added inside the delay oscillation loop. An erbium-doped fibre amplifier (EDFA) is used to adjust the power to be injected into the transmission line. The EDFA is followed by an optical filter (not shown) that cuts off the amplified spontaneous emission noise. All LDs operate at around  $1.55 \mu\text{m}$ . In the all-optical scheme (b), the emitter is a laser diode subject to optical feedback from a digital variable reflector (R). The length of the external cavity is 6 m; a polarization controller (PC) is used within the cavity to adjust the polarization state of the light reflected back from the variable reflector. The message is added via a modulator (MOD) at the emitter's output. A typical transmission module, represented by a fibre loop in the figure, consists of a combination of single-mode and dispersion-compensated fibres, followed by an EDFA that compensates for the power lost upon transmission. In both schemes, decoding is performed via subtraction of the transmitted signal from the signal filtered by the receiver. Operationally, the subtraction is performed by adding the photocurrents coming from an ordinary and a sign-inverting amplified photodiode (PD and IPD, respectively). Fibre connections are represented by thick lines, and electric connections by thin lines. Other elements in the diagram include optical isolators (OI), delay lines (DL), electronic amplifiers (AMP) and optical fibre couplers (OC).

<sup>1</sup>Department of Informatics, University of Athens, Athens 15784, Greece. <sup>2</sup>UMR CNRS 6174, FEMTO-ST / Optics, University of Franche-Comté, 16 route de Gray, 25030 Besançon cedex, France. <sup>3</sup>Department of Electronics, University of Pavia, 27100 Pavia, Italy. <sup>4</sup>Instituto Mediterráneo de Estudios Avanzados, (IMEDEA, CSIC-UIB), Campus UIB, E-07122 Palma de Mallorca, Spain. <sup>5</sup>Institute of Applied Physics, Darmstadt University of Technology, 64289 Darmstadt, Germany. <sup>6</sup>Departament de Física i Enginyeria Nuclear, Universitat Politècnica de Catalunya, E-08222 Terrassa, Spain. <sup>7</sup>Department de Física, Universitat de les Illes Balears, E-07122 Palma de Mallorca, Spain. <sup>8</sup>Instituto de Física de Cantabria (CSIC-UC), Avd de los Castros s/n, E-39005 Santander, Spain. <sup>9</sup>School of Informatics, University of Wales, Bangor LL57 1UT, UK. †Present address: Department of Applied Physics and Photonics, Vrije Universiteit Brussel, Pleinlaan 2, 1050 Brussels, Belgium.

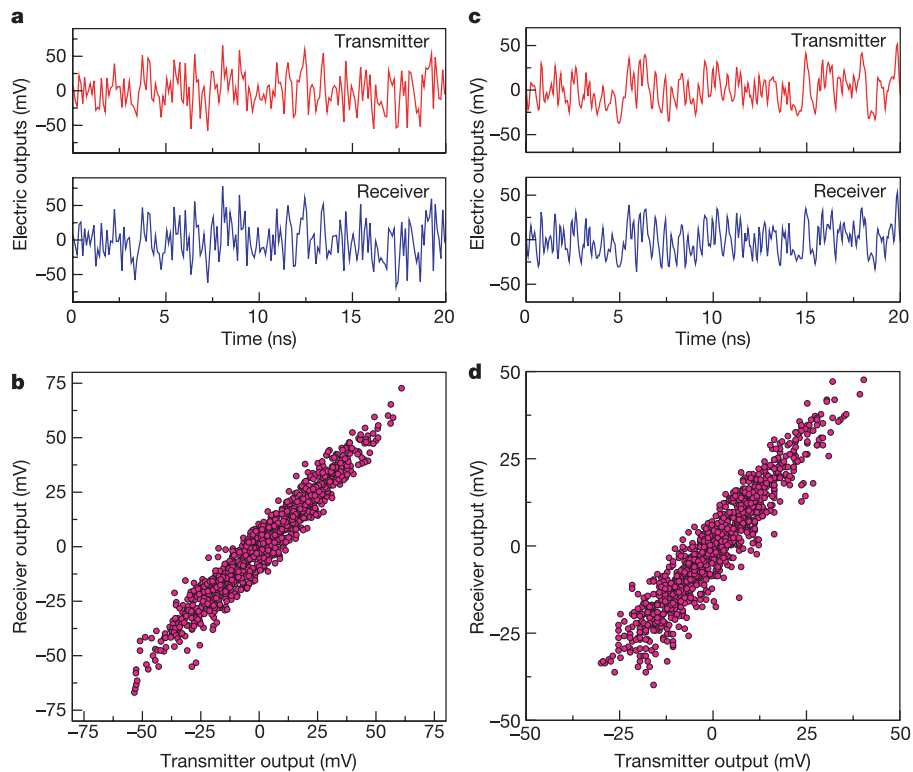

**Figure 2 | Back-to-back synchronization.** Time series (**a** and **c**) and synchronization plots, receiver output power versus transmitter output power (**b** and **d**), of two unidirectionally back-to-back coupled electro-

optical (**a**, **b**) and all-optical (**c**, **d**) systems. Configurations correspond to those depicted in Fig. 1. **b**, **d**, Plots contain 1,000 points, sampled every 100 and 50 ps, respectively.

generate locally a message-free chaotic signal, which is then used for subtraction from the encoded transmitted signal.

Optical systems provide simple ways of generating very high-dimensional chaotic carriers that offer a substantial security level, and also the possibility of very high transmission rates<sup>2</sup>. Early laboratory experiments demonstrated successful back-to-back communications in all-optical<sup>3</sup> and electro-optical<sup>4</sup> systems. High bit rates have been achieved in these back-to-back conditions<sup>5,10</sup>, but no long-distance transmission experiments in commercial communication networks have been undertaken so far. Here we report the achievement of chaotic optical communications over long fibre spans (more than 100 km), at high transmission rates (higher than  $1 \text{ Gb s}^{-1}$ ) and low bit-error rates (lower than  $10^{-7}$ ). We report results from a successful field experiment using part of the metropolitan area network of the city of Athens, Greece.

Generation of chaotic signals with high dimension and high information entropy can be achieved in diode lasers by means of delayed feedback. We have considered two schemes, involving all-optical and electro-optical feedback. In the first scheme (Fig. 1a), the output of a diode laser is used to drive an integrated Mach-Zehnder interferometer that acts as a nonlinear intensity modulator; in the second (Fig. 1b), a diode laser is subject to coherent optical feedback from an external mirror. In both set-ups, a high-dimensional chaotic output is obtained in a large region of parameter space<sup>11,12</sup>. Distributed-feedback lasers are used to ensure single-mode operation.

In the electro-optical scheme encoding is realized by adding the message to the chaotic carrier inside the nonlinear feedback loop (Fig. 1a), whereas in the all optical scheme the chaotic carrier amplitude is modulated with the message (Fig. 1b). In both schemes, the message is decoded by subtracting the total transmitted signal from the output of the receiver laser, which is not subject to feedback (hence the receiver is not chaotic in the absence of the transmitted signal). This architecture is known as an 'open-loop' configuration,

as opposed to the 'closed-loop' scheme in which both transmitter and receiver have feedback. Earlier studies have shown that the open-loop configuration leads to synchronization more readily than the closed-loop one<sup>13,14</sup>. Furthermore, in the all-optical case the closed-loop architecture requires careful tuning of the feedback phase<sup>15,16</sup>.

First we examine the back-to-back performance of the electro-optical communication set-up (see Fig. 1a). The emitter and receiver in this case are two nominally identical distributed-feedback

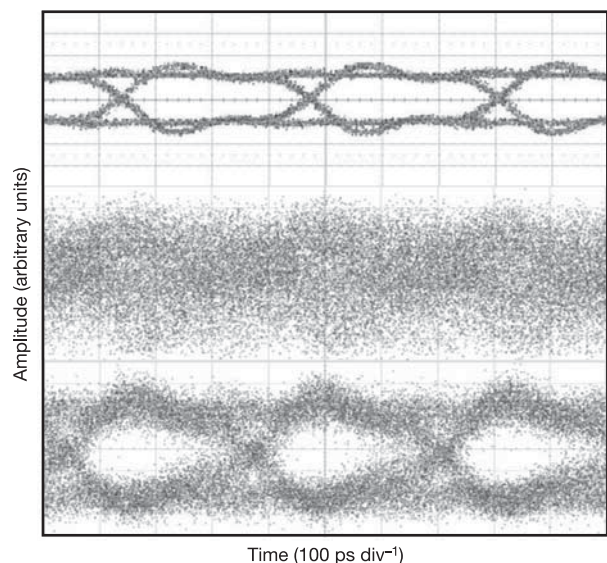

**Figure 3 | Representative eye diagrams in the electro-optic set-up.** The message is shown in the top trace, the encoded signal in the middle trace, and the decoded message in the bottom trace.

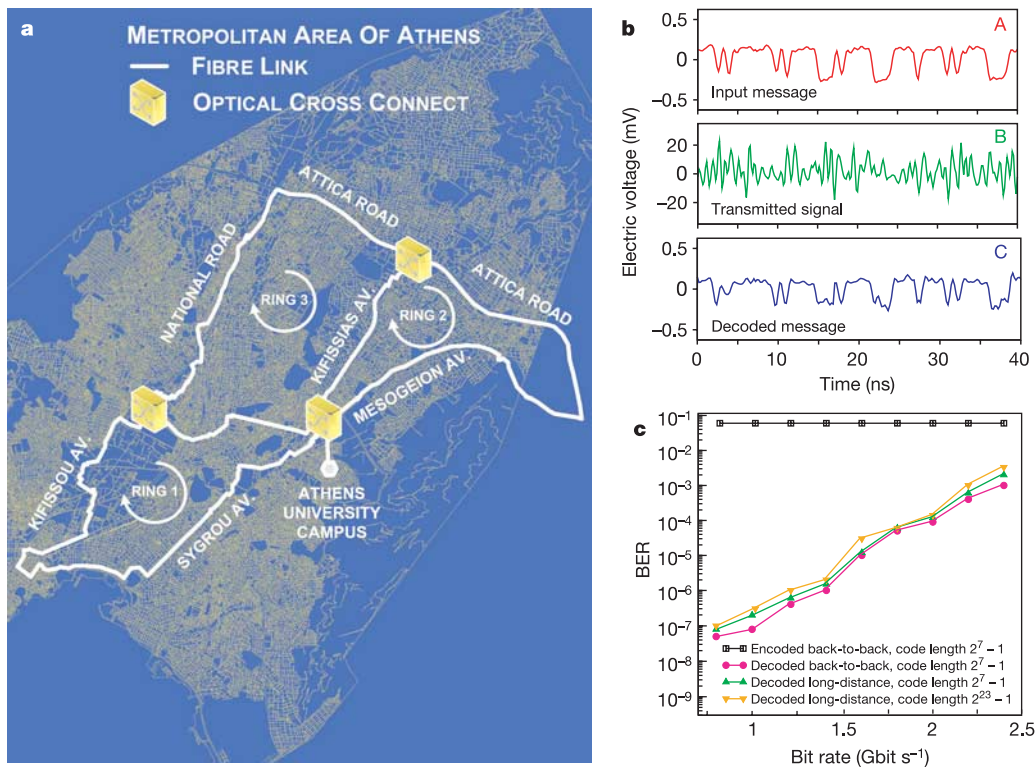

**Figure 4 | Field experiment of fibre transmission.** **a**, Implementation of chaos-encoded communications in the optical communication network of Athens, Greece. **b**, Time traces of a  $1 \text{ Gb s}^{-1}$  applied message (trace A;  $\text{BER} < 10^{-12}$ ), carrier with the encoded message (trace B;  $\text{BER} \approx 6 \times 10^{-2}$ )

and recovered message after 120-km transmission (trace C;  $\text{BER} \approx 10^{-7}$ ). **c**, The BER performance of the encoded signal (squares), back-to-back decoded message (circles) and decoded message after transmission for two different code lengths (triangles).

semiconductor lasers operating at 1552.0 and 1552.9 nm, respectively. The electro-optical feedback produces a chaotic carrier signal with a broad power spectrum. Upon injection of the emitter output into the receiver (which does not have feedback of its own), the receiver also becomes chaotic and synchronizes with the former, as shown in Fig. 2a, b. The corresponding behaviour of the back-to-back all-optical set-up (see Fig. 1b) is represented in Fig. 2c, d. In this case the emission wavelengths of the two lasers have been matched with proper temperature adjustment. A clear synchronization between the emitter and receiver outputs is observed in this case as well.

Synchronization is preserved after propagation through the fibre (results not shown). In particular, we have performed laboratory experiments with two transmission modules consisting of 50 km of single-mode fibre and 6 km of dispersion compensation fibre each. The compensation module was selected to have a total dispersion around  $-850 \text{ ps nm}^{-1}$ , to counterbalance the dispersion of the single-mode fibre (around  $850 \text{ ps nm}^{-1}$ ). Each module is completed with an erbium-doped fibre amplifier whose gain is tuned to provide the necessary power recovery after transmission, followed by an optical filter to remove unwanted amplified spontaneous emission noise.

Figure 3 shows the performance of the electro-optical set-up after transmission. A message in the form of a pseudorandom bit sequence of  $2^7 - 1$  bits is introduced via chaos modulation, as explained above (see Fig. 1a). The bias voltage of the modulator is chosen so that either the 'ones' or 'zeros' have a flattened noise profile, to avoid low-frequency noise that degrades the bit-error rate. Figure 3 shows the eye diagrams (superposition of a large number of bits) of the message and of the encoded and decoded signals after propagation through the transmission modules described in the previous paragraph. Bit-error rates (BER) are of the order of  $10^{-7}$ , for a transmission rate of  $3 \text{ Gb s}^{-1}$ . The performance of the all-optical

scheme in laboratory experiments is similar in terms of BER (see below), for slightly smaller transmission rates (of the order of  $1 \text{ Gb s}^{-1}$ ).

To test performance under 'real-world' conditions we implemented a chaos-based all-optical transmission system using an installed optical network infrastructure of single-mode fibre belonging to the metropolitan area network of Athens. The network has a total length of 120 km and was provided by Attika Telecom SA. The topology consists of three fibre rings, linked together at specific cross-connect points (see Fig. 4a). Through three cross-connect points, the transmission path follows the Ring-1 route, then the Ring-2 route, and finally the Ring-3 route. A dispersion compensation fibre module, set at the beginning of the link (pre-compensation technique), cancels the chromatic dispersion that would be induced by the single-mode fibre transmission. Erbium-doped fibre amplifiers and optical filters are used along the optical link for compensation of the optical losses and filtering of amplified spontaneous emission noise, respectively. The pair of lasers is selected to exhibit parameter mismatches that are constrained below 3%. The mean optical power injected into the receiver has been limited to 0.8 mW, to avoid possible damage of the antireflective coating of the slave laser.

A non-return-to-zero pseudorandom bit sequence is applied by externally modulating the chaotic carrier by means of a  $\text{LiNbO}_3$  Mach-Zehnder modulator. The message amplitude is attenuated 14 dB with respect to the carrier, so the BER of the transmitted signal after filtering (but without the appropriate decoding) is always larger than  $6 \times 10^{-2}$ , this value being the instrumentation limit (the maximum BER of the error detector is  $9 \times 10^{-2}$ ). A good synchronization performance of the transmitter-receiver set-up leads to an efficient cancellation of the chaotic carrier, and hence to a satisfactory decoding process (see Fig. 4b). The performance of the chaotic transmission system has been studied for different message bit rates up to  $2.4 \text{ Gb s}^{-1}$  and for two different code lengths:  $2^7 - 1$



and  $2^{23} - 1$ . All BER values have been measured after filtering the subtracted electric signal, by using low-pass filters with bandwidth adjusted each time to the message bit rate. For transmission rates in the gigabit per second range the recovered message exhibits BER values lower than  $10^{-7}$ . For higher transmission rates the corresponding bit-error rates increase, as shown in Fig. 4c. This is due to the fact that the synchronization is not perfect, mainly because of parameter differences between the two lasers. Moreover, signal extraction is less efficient at bit rates comparable to the relaxation oscillation frequencies of the lasers (in our case around 3 GHz). For properly chosen lasers (that is, with much higher relaxation frequency and better parameter matching) this BER deterioration could be avoided to a large extent, and BER values could approach the ones of traditional communication systems, which lie between  $10^{-9}$  and  $10^{-12}$ .

When the code length increases from  $2^7 - 1$  to  $2^{23} - 1$  bits, only a minor increase in BER is observed. Also, relatively small differences in the BER values exist between the back-to-back and the transmission set-ups, revealing only a slight degradation of the system performance due to the transmission link. Communication bit rates are mainly limited by the bandwidth of the chaotic carrier, which depends on the emitter components. Nevertheless, this bandwidth can extend well beyond the relaxation frequency of the emitter laser. In our electro-optical set-up the bandwidth is about 7 GHz, and in the all-optical set-up it is 5 GHz.

The results reported here provide a convincing proof-of-practical-concept for optical chaos communications technology. Building on this, it should be possible to develop reliable cost-effective secure communications systems that exploit deeper properties of chaotic dynamics<sup>17</sup>. Opportunities for such technological advances have emerged from the substantial theoretical and experimental advances accomplished within the OCCULT project (<http://nova.uib.es/project/occult>) and in other laboratories around the world<sup>18–20</sup>.

The prototype technology that has been developed would benefit from added intelligence features. It will be essential to develop a meaningful measure of the security provided by any proposed secure communications technology—one capable of useful comparison with other technologies. Beyond that, we envisage opportunities for effecting fundamental advances in chaos synchronization techniques, using smart encryption techniques<sup>16</sup>, developing active eavesdropper-evasion strategies, designing compact transmitter/receiver modules, as well as implementing robust technology for bidirectional chaotic communications, chaotic message broadcasting<sup>21</sup>, parallel communications with spatiotemporal chaos<sup>22,23</sup>, and frequency multiplexing through sharing of the chaotic broadband spectrum<sup>24</sup>. In addition, chaos communication systems are fully compatible with the widely used wavelength division multiplexing (WDM), provided the chaotic carrier bandwidth is much smaller than the WDM channel spacing. In combination, such advances should enable the delivery of practical systems for intelligent chaotic optical data encoding and lead to deeper fundamental insight into communication between systems with irregular or even adaptive signals.

Received 11 July; accepted 26 September 2005.

1. Cuomo, K. M., Oppenheim, A. V. & Strogatz, S. H. Synchronization of Lorenz-based chaotic circuits with applications to communications. *IEEE Trans. Circuits Syst. II* **40**, 626–633 (1993).

2. Colet, P. & Roy, R. Digital communication with synchronized chaotic lasers. *Opt. Lett.* **19**, 2056–2058 (1994).
3. Van Wiggeren, G. D. & Roy, R. Communications with chaotic lasers. *Science* **279**, 1198–1200 (1998).
4. Goedgebuer, J. P., Larger, L. & Porte, H. Optical cryptosystem based on synchronization of hyperchaos generated by a delayed feedback tunable laser diode. *Phys. Rev. Lett.* **80**, 2249–2252 (1998).
5. Tang, S. & Liu, J. M. Message encoding–decoding at 2.5 Gbits/s through synchronization of chaotic pulsing semiconductor lasers. *Opt. Lett.* **26**, 1843–1845 (2001).
6. Shannon, C. E. Communication theory of secrecy systems. *Bell Syst. Technic. J.* **28–4**, 656–715 (1949).
7. Kurtsiefer, C. *et al.* A step towards global key distribution. *Nature* **419**, 450 (2002).
8. Ashwin, P. Synchronization from chaos. *Nature* **422**, 384–385 (2003).
9. Mirasso, C. R., Colet, P. & Garcia-Fernandez, P. Synchronization of chaotic semiconductor lasers: Application to encoded communications. *IEEE Photon. Technol. Lett.* **8**, 299–301 (1996).
10. Kusumoto, K. & Ohtsubo, J. 1.5-GHz message transmission based on synchronization of chaos in semiconductor lasers. *Opt. Lett.* **27**, 989–991 (2002).
11. Annovazzi-Lodi, V., Merlo, S., Norgia, M. & Scirè, A. Characterization of a chaotic telecommunication laser for different fiber cavity lengths. *IEEE J. Quant. Electron.* **38**, 1171–1177 (2002).
12. Lee, M. W., Larger, L. & Goedgebuer, J. P. Transmission system using chaotic delays between lightwaves. *IEEE J. Quant. Electron.* **39**, 931–936 (2003).
13. Vicente, R., Pérez, T. & Mirasso, C. R. Open- versus closed-loop performance of synchronized chaotic external-cavity semiconductor lasers. *IEEE J. Quant. Electron.* **38**, 1197–1204 (2002).
14. Lee, M. W., Paul, J., Sivaprakasam, S. & Shore, K. A. Comparison of closed-loop and open-loop feedback schemes of message decoding using chaotic laser diodes. *Opt. Lett.* **28**, 2168–2170 (2003).
15. Peil, M., Heil, T., Fischer, I. & Elsässer, W. Synchronization of chaotic semiconductor laser systems: a vectorial coupling-dependent scenario. *Phys. Rev. Lett.* **88**, 174101 (2002).
16. Heil, T. *et al.* ON/OFF phase shift keying for chaos-encrypted communication using external-cavity semiconductor lasers. *IEEE J. Quant. Electron.* **38**, 1162–1170 (2002).
17. Annovazzi Lodi, V., Benedetti, M., Merlo, S. & Provinzano, M. N. B. Optical chaos masking of video signals. *IEEE Photon. Technol. Lett.* **17**, 1995–1997 (2005).
18. Donati, S. & Mirasso, C. R. (eds) Feature section on optical chaos and applications to cryptography. *IEEE J. Quant. Electron.* **39**, 1138–1204 (2002).
19. Larger, L. & Goedgebuer, J. P. (eds) Cryptography using optical chaos. *C.R. Phys.* **5**, 609–681 (2004).
20. Uchida, A., Rogister, F., Garcia-Ojalvo, J. & Roy, R. Synchronization and communication with chaotic optical systems. *Prog. Opt.* **48**, 203–341 (2005).
21. Lee, M. W. & Shore, K. A. Chaotic message broadcasting using DFB laser diodes. *Electron. Lett.* **40**, 614–615 (2004).
22. Gollub, J. P. & Cross, M. C. Chaos in space and time. *Nature* **404**, 710–711 (2000).
23. Garcia-Ojalvo, J. & Roy, R. Spatiotemporal communication with synchronized optical chaos. *Phys. Rev. Lett.* **86**, 5204–5207 (2001).
24. Matsuura, T., Uchida, A. & Yoshimori, S. Chaotic wavelength division multiplexing for optical communications. *Opt. Lett.* **29**, 2731–2733 (2004).

**Acknowledgements** Financial support was provided by the European Commission through the IST project OCCULT. We thank ATTICA TELECOMMS SA for providing the installed fibre infrastructure for the field experiment, and S. Hansmann and J. Schumacher for providing the matched laser and detector pairs. We thank S. H. Strogatz for a careful reading of the manuscript. We are also grateful for the collaboration of J. P. Goedgebuer, W. Elsässer, M. Peil, S. Poinot, M. Benedetti, S. Merlo, M. Norgia, M. W. Lee, Y. Chembo Kouomou, T. Pérez, R. Vicente, J. Mulet, J. M. Buldú, M. C. Torrent, S. Ortin and the rest of the participants of the OCCULT project.

**Author Information** Reprints and permissions information is available at [npg.nature.com/reprintsandpermissions](http://npg.nature.com/reprintsandpermissions). The authors declare no competing financial interests. Correspondence and requests for materials should be addressed to C.R.M. ([claudio@galiota.uib.es](mailto:claudio@galiota.uib.es)).